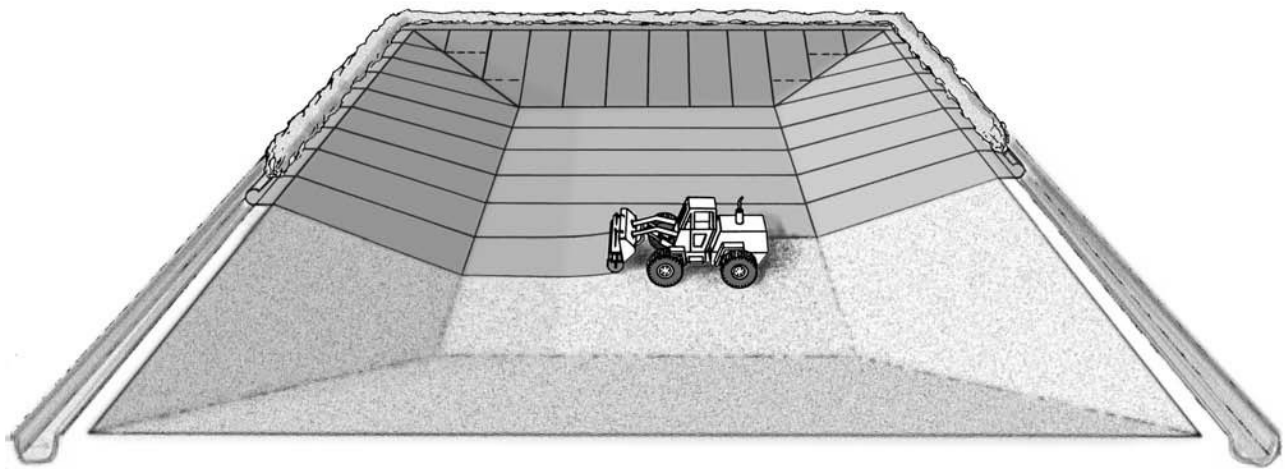


## Installation Guidelines



# BENTOMAT<sup>®</sup> CLAYMAX<sup>®</sup>

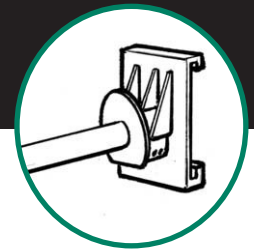
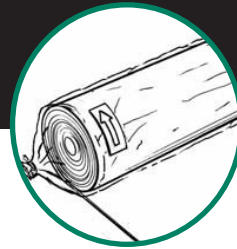
Geosynthetic Clay Liners



**NOTICE:** This document is intended for use as a GENERAL GUIDELINE for the installation of CETCO's GCLs. The information and data contained herein are believed to be accurate and reliable. CETCO makes no warranty of any kind and accepts no responsibility for the results obtained through application of this information. Installation guidelines are subject to periodic changes. Please consult our CETCO Engineering Website @ [www.cetco.com/LTE](http://www.cetco.com/LTE) for the most recent version.



# TABLE OF CONTENTS



1. Introduction . . . . .	3
2. Equipment Requirements . . . . .	3
3. Shipping, Unloading, and Storage . . . . .	5
4. Subgrade Preparation . . . . .	6
5. Installation . . . . .	7
6. Anchorage . . . . .	9
7. Seaming . . . . .	10
8. Sealing Around Penetrations and Structures . . . . .	11
9. Damage Repair . . . . .	14
10. Cover Placement . . . . .	14
11. Hydration . . . . .	15



- 1.1** This document provides procedures for the installation of CETCO's GCLs in a manner that maximizes safety, efficiency, and the physical integrity of the GCL.
- 1.2** These guidelines are based upon many years of experience at a variety of sites and should be generally applicable to any type of lining project using CETCO's GCLs. Variance from these guidelines is at the engineer's discretion.
- 1.3** The performance of the GCL is wholly dependent on the quality of its installation. It is the installer's responsibility to adhere to these guidelines, and to the project specifications and drawings, as closely as possible. It is the engineer's and owner's responsibility to provide construction quality assurance (CQA) for the installation, to ensure that the installation has been executed properly. This document covers only installation procedures.
- 1.4** For additional guidance, refer to ASTM D5888 (Standard Guide For Storage and Handling of Geosynthetic Clay Liners) and ASTM D 6102 (Standard Guide For Installation of Geosynthetic Clay Liners).

## EQUIPMENT REQUIREMENTS

- 2.1** CETCO GCLs are delivered in rolls typically 2,600-2,950 lbs (1180-1340 kg). Roll dimensions and weights will vary with the dimensions of the product ordered. It is necessary to support this weight using an appropriate core pipe as indicated in Table 1. For any installation, the core pipe must not deflect more than 3 inches (75 mm) as measured from end to midpoint when a full GCL roll is lifted.

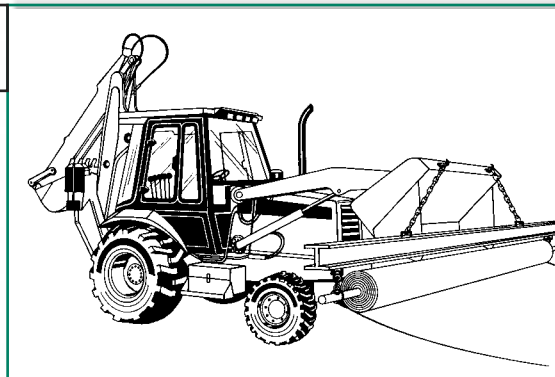
**TABLE 1 CORE REQUIREMENTS**

Product(s)	Nominal GCL Roll Size W x Dia. Ft. (m) x in. (mm)	Typical GCL Roll Wt., lbs. (kg)	Interior Core Size, in. (mm)	Core Pipe Length x Diameter, ft. x in. (m x mm)	Minimum Core Pipe Strength
Bentomat DN, SDN	16' x 24" (4.9 x 610)	2,650 (1200)	3 3/4 (100)	20 x 2.88"O.D.(6.1 m x 73 mm)	XXH
Bentomat ST	16' x 24" (4.9 x 610)	2,600 (1180)	3 3/4 (100)	20 x 2.88"O.D.(6.1 m x 73 mm)	XXH
Bentomat CLT	16' x 26" (4.9 x 660)	2,950 (1340)	3 3/4 (100)	20 x 2.88"O.D.(6.1 m x 73 mm)	XXH
Claymax 200R	16' x 20" (4.9 x 510)	2,750 (1250)	3 3/4 (100)	20 x 2.88"O.D.(6.1 m x 73 mm)	XXH
Bentomat CL	16' x 25" (4.9 x 635)	2,675 (1213)	3 3/4 (100)	20 x 2.88"O.D.(6.1 m x 73 mm)	XXH



2.2 Lifting chains or straps appropriately rated should be used in combination with a spreader bar made from an I-beam as shown in Figure 1.

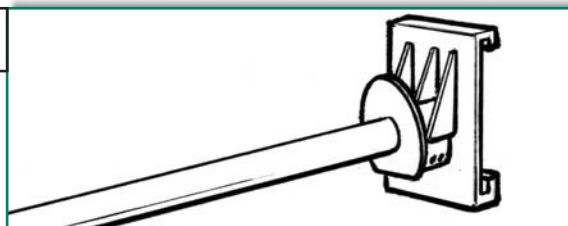
**FIGURE 1** **SPREADER BAR LIFTING ASSEMBLY**



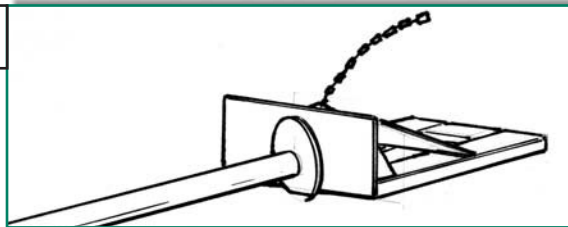
2.3 The spreader bar ensures that lifting chains or straps do not chafe against the ends of the GCL roll, allowing it to rotate freely during installation. Spreader bar and core pipe kits are available through CETCO.

2.4 A front end loader, backhoe, dozer, or other equipment can be utilized with the spreader bar and core pipe or slings. Alternatively, a forklift with a “stinger” attachment may be used for on-site handling. A forklift without a stinger attachment should not be used to lift or handle the GCL rolls. Stinger attachments (Figure 2-4) are specially fabricated to fit various forklift makes and models.

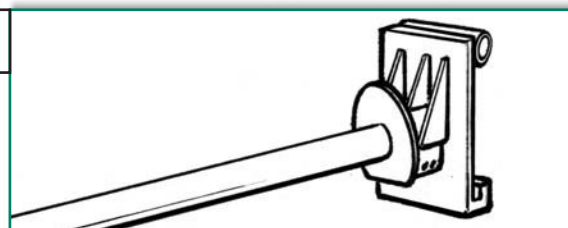
**FIGURE 2** **HOOK MOUNT**


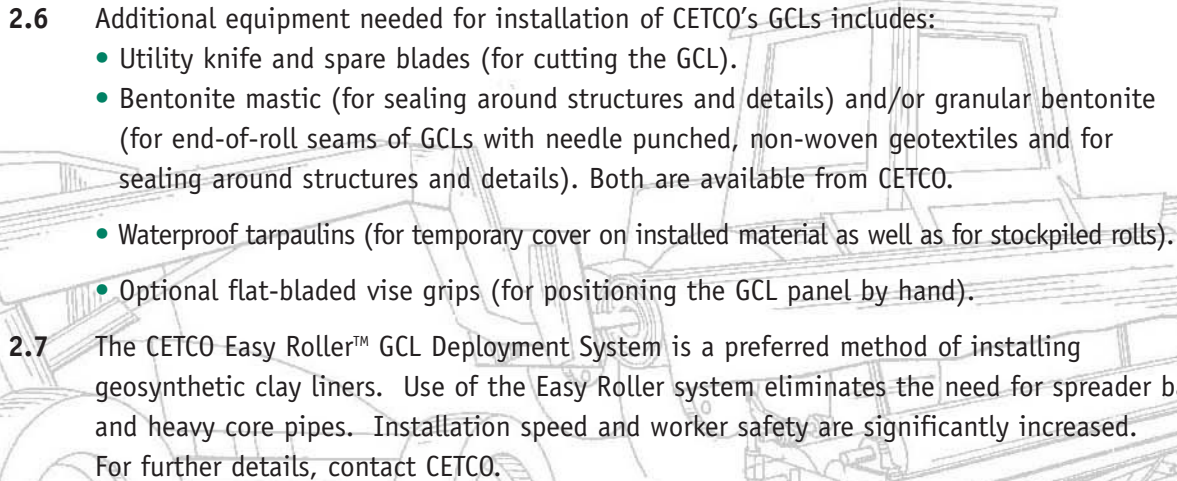


**FIGURE 3** **FORK MOUNT**  
(with fork pockets)




**FIGURE 4** **PIN MOUNT**



- 
- 
- 2.5 When installing over certain geosynthetic materials, a 4-wheel, all-terrain vehicle (ATV) can be used to deploy the GCL. An ATV can be driven directly on the GCL provided that no sudden stops, starts, or turns are made.
- 2.6 Additional equipment needed for installation of CETCO's GCLs includes:
- Utility knife and spare blades (for cutting the GCL).
  - Bentonite mastic (for sealing around structures and details) and/or granular bentonite (for end-of-roll seams of GCLs with needle punched, non-woven geotextiles and for sealing around structures and details). Both are available from CETCO.
  - Waterproof tarpaulins (for temporary cover on installed material as well as for stockpiled rolls).
  - Optional flat-bladed vise grips (for positioning the GCL panel by hand).
- 2.7 The CETCO Easy Roller™ GCL Deployment System is a preferred method of installing geosynthetic clay liners. Use of the Easy Roller system eliminates the need for spreader bars and heavy core pipes. Installation speed and worker safety are significantly increased. For further details, contact CETCO.

### 3 SHIPPING, UNLOADING & STORAGE

- 3.1 All lot and roll numbers should be recorded and compared to the packing list. Each roll of GCL should also be visually inspected during unloading to determine if any packaging has been damaged. Damage, whether obvious or suspected, should be recorded and the affected rolls marked.
- 3.2 Major damage suspected to have occurred during transit should be reported immediately to the carrier and to CETCO. The nature of the damage should also be indicated on the bill of lading with the specific lot and roll numbers. Accumulation of some moisture within roll packaging is normal and does not damage the product.
- 3.3 The party directly responsible for unloading the GCL should refer to this manual prior to shipment to ascertain the appropriateness of their unloading equipment and procedures. Unloading and on-site handling of the GCL should be supervised.
- 3.4 In most cases, CETCO GCLs are delivered on flatbed trucks. There are three methods of unloading: core pipe and spreader bar; slings; or stinger bar. To unload the rolls from the flatbed using a core pipe and spreader bar, first insert the core pipe through the core tube. Secure the lifting chains or straps to each end of the core pipe and to the spreader bar mounted on the lifting equipment. Hoist the roll straight up and make sure its weight is evenly distributed so that it does not tilt or sway when lifted.
- 3.5 At the customer's request, CETCO GCLs may be delivered with two 2" x 12' (50 mm x 3.65 m) Type V polyester endless slings on each roll. Before lifting, check the position of the slings. Each sling should be tied off in the choke position approximately one third (1/3) from the end of the roll. Hoist the roll straight up so that it does not tilt or sway when lifted.
- 



- 3.6 In some cases, GCL rolls will be stacked in three pyramids on flatbed trucks. If slings are not used, rolls will require unloading with a stinger bar and extendible boom fork lift. Spreader bars will not work in this situation because of the limited access between the stacks of GCL. Three types of stingers are available from CETCO (Figures 2-4). To unload, guide the stinger through the core tube before lifting the GCL roll and removing from the truck.
- 3.7 An extendible boom fork lift with a stinger bar is required for unloading vans. Rolls in the nose and center of van should first be carefully pulled toward the door using the slings provided on the rolls.
- 3.8 Rolls should be stored at the job site away from high-traffic areas but sufficiently close to the active work area to minimize handling. The designated storage area should be flat, dry and stable. Moisture protection of the GCL is provided by its packaging; however, an additional tarpaulin or plastic sheet is recommended.
- 3.9 Rolls should be stacked in a manner that prevents them from sliding or rolling. This can be accomplished by chocking the bottom layer of rolls. Rolls should be stacked no higher than the height at which they can be safely handled by laborers (typically no higher than four layers of rolls). Rolls should never be stacked on end.

## 4

### SUBGRADE PREPARATION

- 4.1 Subgrade surfaces consisting of granular soils or gravel may not be acceptable due to their large void fraction and puncture potential. In high-head (greater than one foot or 30 cm) applications, subgrade soils should possess a particle size distribution such that at least 80 percent of the soil is finer than a #60 sieve (0.250 mm) unless a membrane-laminated GCL (Bentomat CL or Bentomat CLT) is used.
- 4.2 When the GCL is placed over an earthen subgrade, the subgrade surface must be prepared in accordance with the project specifications. The engineer's approval of the subgrade must be obtained prior to installation. The finished surface should be firm and unyielding, without abrupt elevation changes, voids, cracks, ice, or standing water.
- 4.3 The subgrade surface must be smooth and free of vegetation, sharp-edged rocks, stones, sticks, construction debris, and other foreign matter that could contact the GCL. The subgrade should be rolled with a smooth-drum compactor to remove any wheel ruts greater than 1 inch in depth, footprints, or other abrupt grade changes. Furthermore, all protrusions extending more than 0.5 inch (12 mm) from the subgrade surface shall be removed, crushed, or pushed into the surface with a smooth-drum compactor. The GCL may be installed on a frozen subgrade, but the subgrade soil in the unfrozen state should meet the above requirements.



- 5.1 GCL rolls should be taken to the work area of the site in their original packaging. The orientation of the GCL (i.e., which side faces up) may be important if the GCL has two different types of geosynthetics. Check with the project engineer in order to determine if there is a preferred installation orientation for the GCL. If no specific orientation is required, allow the roll to unwind from the bottom rather than pulling from the top (Figure 5). The arrow sticker on the plastic sleeve indicates the direction the GCL will naturally unroll when placed on the ground (Figure 6). Prior to deployment, the packaging should be carefully removed without damaging the GCL.

FIGURE 5

**THE GCL CAN BE UNROLLED IN ITS “NATURAL” ORIENTATION (A) OR CAN BE PULLED FROM THE TOP OF THE ROLL (B)**

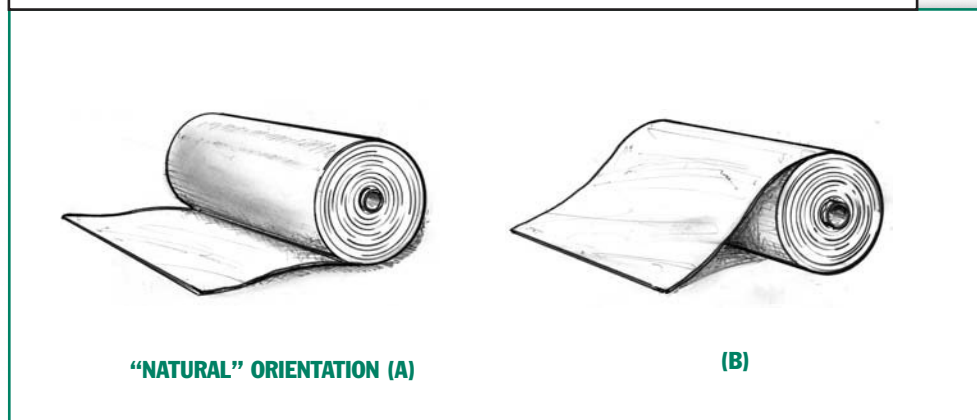
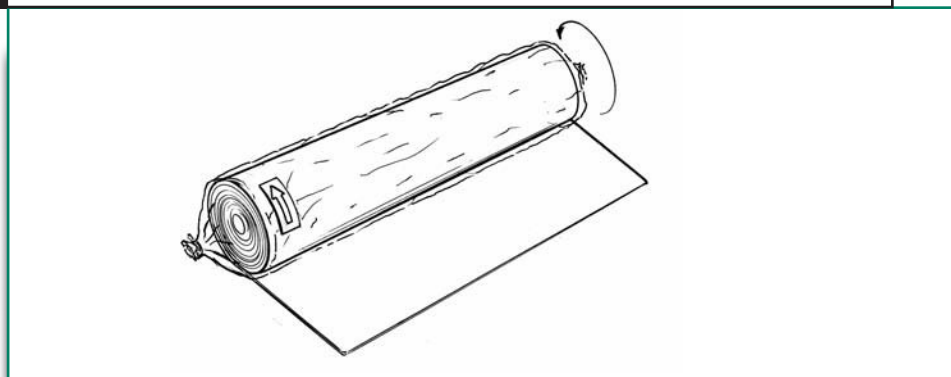


FIGURE 6

**DIRECTION TO UNROLL GCL ON GROUND PER FIGURE 5(A)**

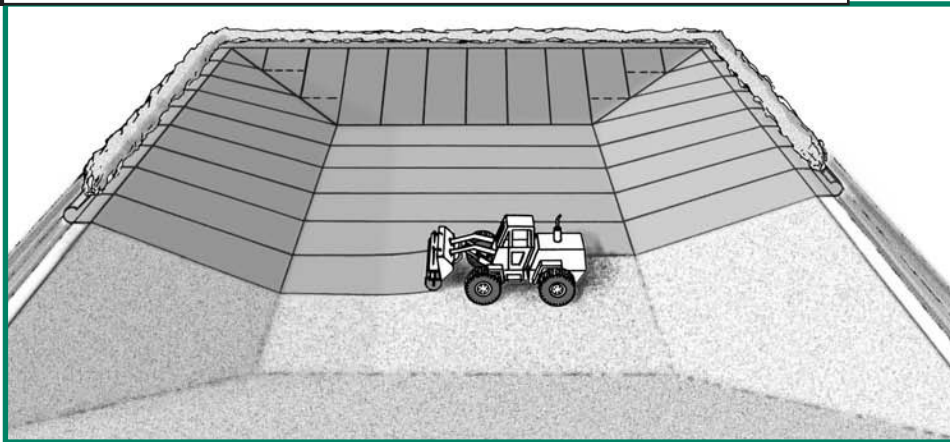


- 5.2 Equipment which could damage the GCL should not be allowed to travel directly on it. Acceptable installation, therefore, may be accomplished such that the GCL is unrolled in front of backwards-moving equipment (Figure 7). If the installation equipment causes rutting of the subgrade, the subgrade must be restored to its originally accepted condition before placement continues.



**FIGURE 7**

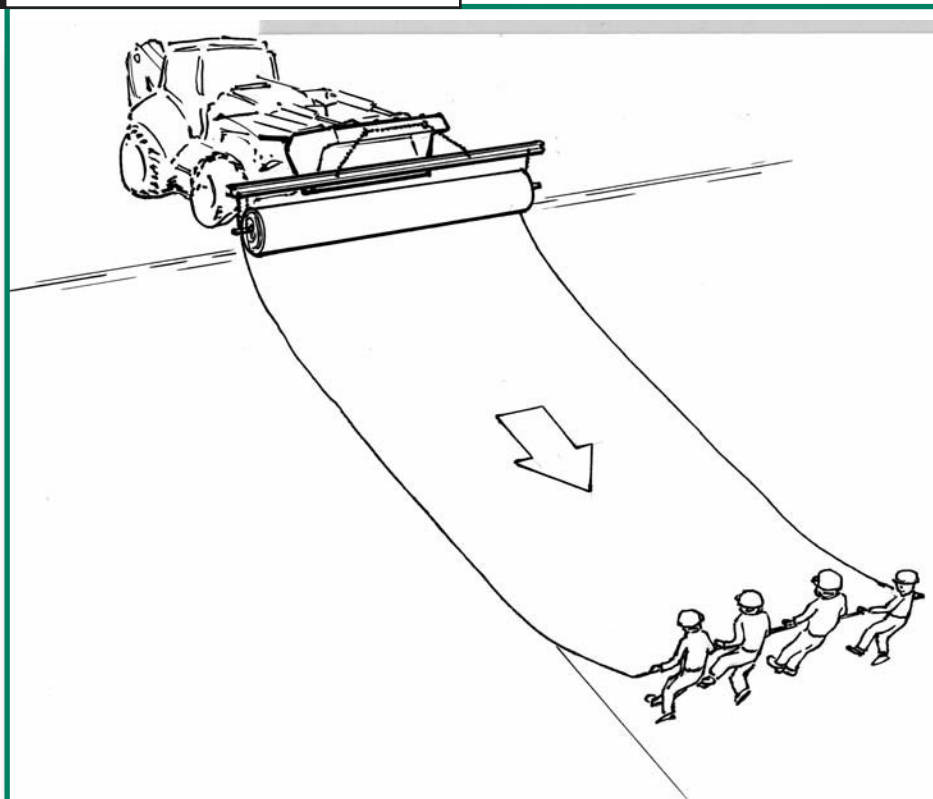
**TYPICAL BENTOMAT®/CLAYMAX® INSTALLATION TECHNIQUE**



- 5.3 If sufficient access is available, GCL may be deployed by suspending the roll at the top of the slope with a group of laborers pulling the material off of the roll and down the slope (Figure 8).
- 5.4 GCL rolls should not be released on the slope and allowed to unroll freely by gravity.
- 5.5 Care must be taken to minimize the extent to which the GCL is dragged across the subgrade in order to avoid damage to the bottom surface of the GCL. Care must also be taken when adjusting Bentomat CLT panels to avoid damage to the geotextile surface of one panel of GCL by the textured sheet of another panel of GCL. A temporary geosynthetic subgrade covering, commonly known as a slip sheet or rub sheet, may be used to reduce friction damage during placement.

**FIGURE 8**

**UNROLLING BENTOMAT**



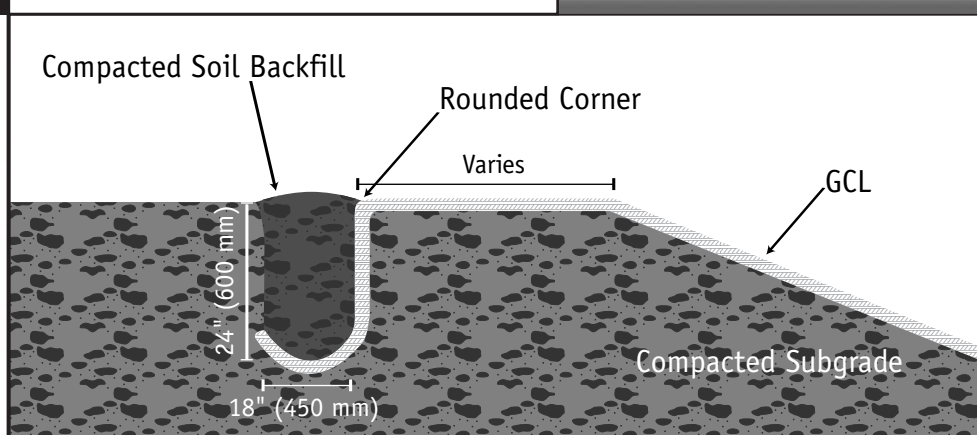


- 5.6 The GCL should be placed so that seams are parallel to the direction of the slope. End-of-panel seams should also be located at least 3 ft (1m) from the toe and crest of slopes steeper than 4H:1V. End-of-roll seams on slopes should be used only if the liner is not expected to be in tension.
- 5.7 All GCL panels should lie flat, with no wrinkles or folds, especially at the exposed edges of the panels. When Bentomat with SuperGroove® is repositioned, it should be gripped inside the SuperGroove by folding the edge.
- 5.8 The GCL should not be installed in standing water or during rainy weather. Only as much GCL shall be deployed as can be covered at the end of the working day with soil, geomembrane, or a temporary waterproof tarpaulin. The GCL shall not be left uncovered overnight. If the GCL is hydrated when no confining stress is present, it may be necessary to remove and replace the hydrated material. CETCO recommends that premature hydration be evaluated on a case-by-case basis. The project engineer, CQA inspector, and CETCO's TR-312 should be consulted for specific guidance if premature hydration occurs. The type of GCL, duration of exposure, degree of hydration, location in the liner system, and expected bearing loads should be considered. In many instances, a needlepunch reinforced GCL may not require removal/replacement if the following are true: (1) the geotextiles have not been separated, torn or otherwise damaged; (2) there is no evidence that the needlepunching between the two geotextiles has been compromised; (3) the Bentomat does not leave deep indentations when stepped upon; and (4) any overlapped seams with bentonite enhancement (see Section 7) are intact.
- 5.9 For the convenience of the installer, hash marks are placed on Bentomat every 5' (1.5 m) of length.

## 6 ANCHORAGE

- 6.1 If required by the project drawings, the end of the GCL roll should be placed in an anchor trench at the top of a slope. The front edge of the trench should be rounded to eliminate any sharp corners that could cause excessive stress on the GCL. Loose soil should be removed or compacted into the floor of the trench.

**FIGURE 9** TYPICAL ANCHOR TRENCH DESIGN





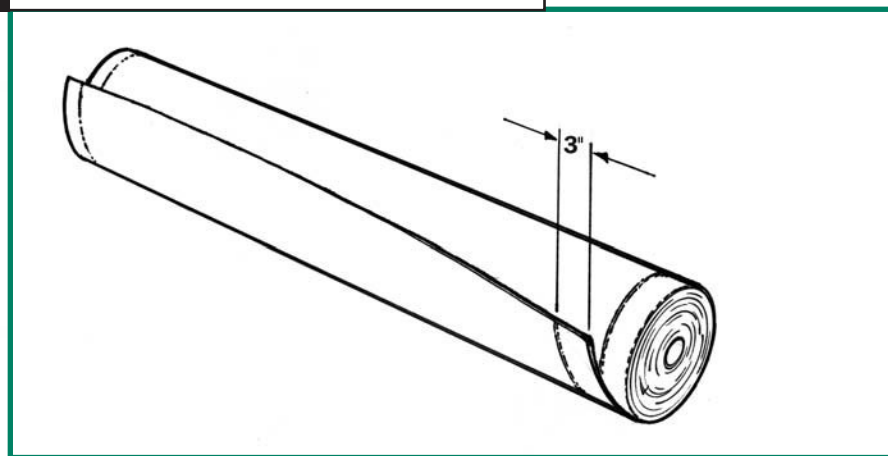
- 6.2 If a trench is used for anchoring the end of the GCL, soil backfill should be placed in the trench to provide resistance against pullout. The size and shape of the trench, as well as the appropriate backfill procedures, should be in accordance with the project drawings and specifications. Typical dimensions are shown in Figure 9.
- 6.3 The GCL should be placed in the anchor trench such that it covers the entire trench floor but does not extend up the rear trench wall.
- 6.4 Sufficient anchorage may alternately be obtained by extending the end of the GCL roll back from the crest of the slope, and placing cover soil. The length of this “runout” anchor should be prepared in accordance with project drawings and specifications.

## 7

### SEAMING

- 7.1 GCL seams are constructed by overlapping adjacent panel edges and ends. Care should be taken to ensure that the overlap zone is not contaminated with loose soil or other debris. Supplemental bentonite is not required for Claymax 200R. Bentomat ST, DN, and SDN with Supergroove® have self-seaming capabilities in their longitudinal overlaps (Figure 10) and do not require supplemental bentonite. For pond applications, supplemental bentonite must be used in longitudinal seams regardless of the CETCO GCL used.

**FIGURE 10** SUPERGROOVE

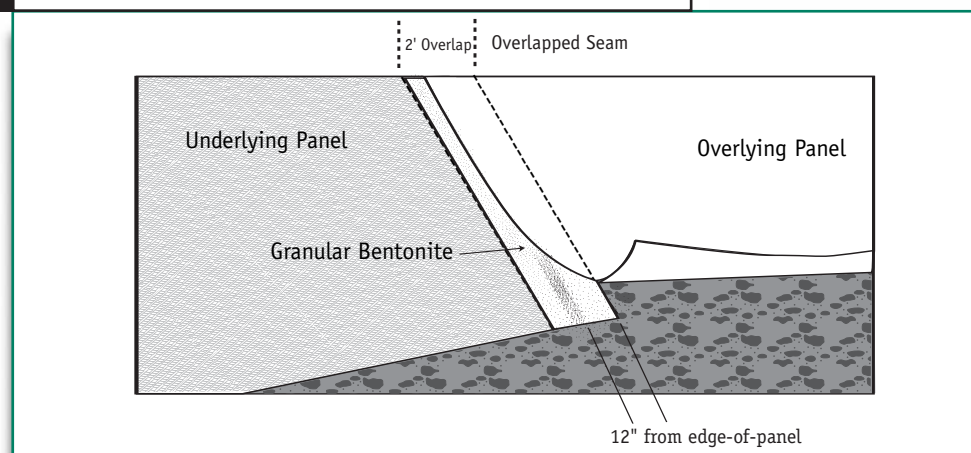


- 7.2 Longitudinal seams should be overlapped a minimum of 6 inches (150mm) for Bentomat and 12 inches (300mm) for Claymax.
- 7.3 End-of-panel overlapped seams should be overlapped 24 inches (600mm) for Bentomat and 48 inches (1,200mm) for Claymax.



- 7.4 End-of-panel overlapped seams are constructed such that they are shingled in the direction of the grade to prevent runoff from entering the overlap zone. End-of-panel seams on slopes are permissible, provided adequate slope stability analysis has been conducted (i.e., the GCL is not expected to be in tension). Bentonite-enhanced seams are required for all Bentomat end-of-panel overlapped seams.
- 7.5 Bentomat end-of-panel, bentonite-enhanced, overlapped seams are constructed first by overlapping the adjacent panels, exposing the underlying panel, and then applying a continuous bead or fillet of granular sodium bentonite 12" from the edge of the underlying panel (Figure 11). The minimum application rate at which the bentonite is applied is one-quarter pound per linear foot (0.4 kg/m).
- 7.6 If longitudinal bentonite enhanced seams are required, they are constructed first by overlapping the adjacent panels by a minimum 6-inches (150 mm), exposing the underlying edge and applying a continuous bead of granular bentonite approximately 3-inches (75 mm) from the edge. The minimum application rate for the granular bentonite is one quarter pound per linear foot (0.4 kg/m).

**FIGURE 11 BENTOMAT END-OF-PANEL OVERLAPPED SEAM**



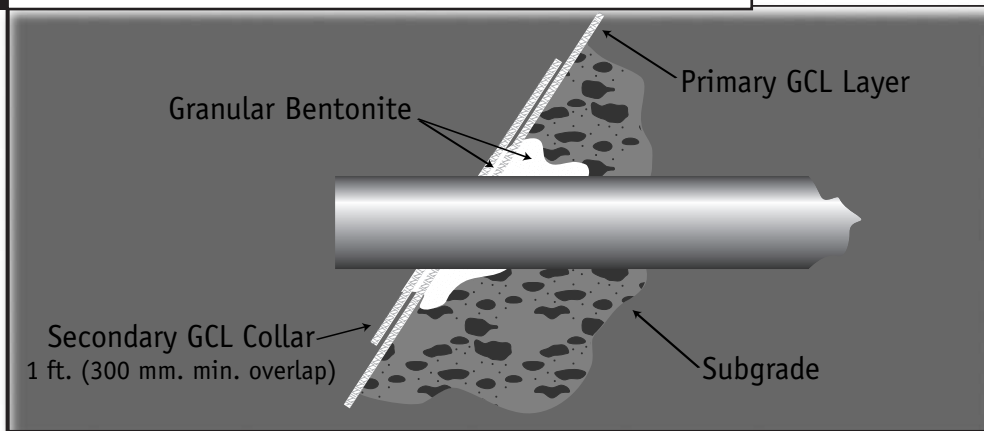
**8**

**SEALING AROUND PENETRATIONS AND STRUCTURES**

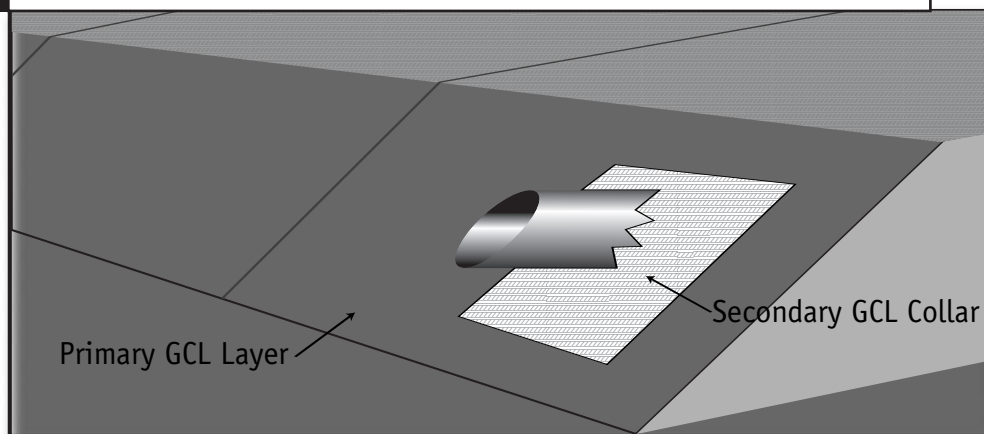
- 8.1 Cutting the GCL should be performed using a sharp utility knife. Frequent blade changes are recommended to avoid irregular tearing of the geotextile components of the GCL during the cutting process.
- 8.2 The GCL should be sealed around penetrations and structures embedded in the subgrade in accordance with Figures 12 through 14. Granular bentonite or a bentonite mastic shall be used liberally (approx. 2 lbs. /ln ft. or 3 kg/m) to seal the GCL to these structures.



**FIGURE 12A** CROSS-SECTION OF A HORIZONTAL PIPE PENETRATION

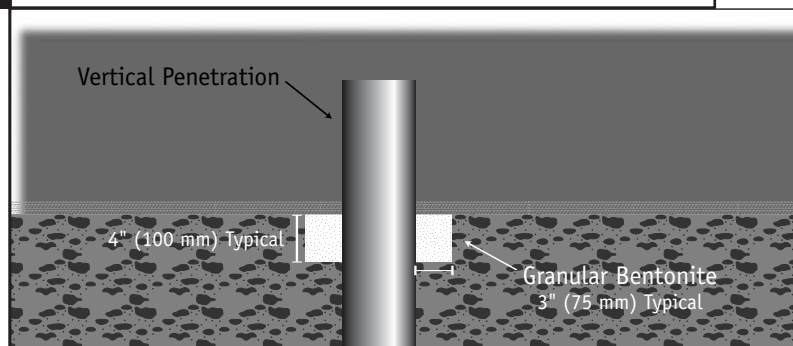


**FIGURE 12B** ISOMETRIC VIEW OF A COMPLETED HORIZONTAL PIPE PENETRATION



- 8.3 When the GCL is placed over a horizontal pipe penetration, a “notch” should be excavated into the subgrade around the penetration (Figure 12a). The notch should then be backfilled with granular bentonite. A secondary collar of GCL should be placed around the penetration as shown in Figure 12b. It is helpful to first trace an outline of the penetration on the GCL and then cut a “star” pattern in the collar to enhance the collar’s fit to the penetration. Granular bentonite should be applied between the primary GCL layer and the secondary GCL collar.

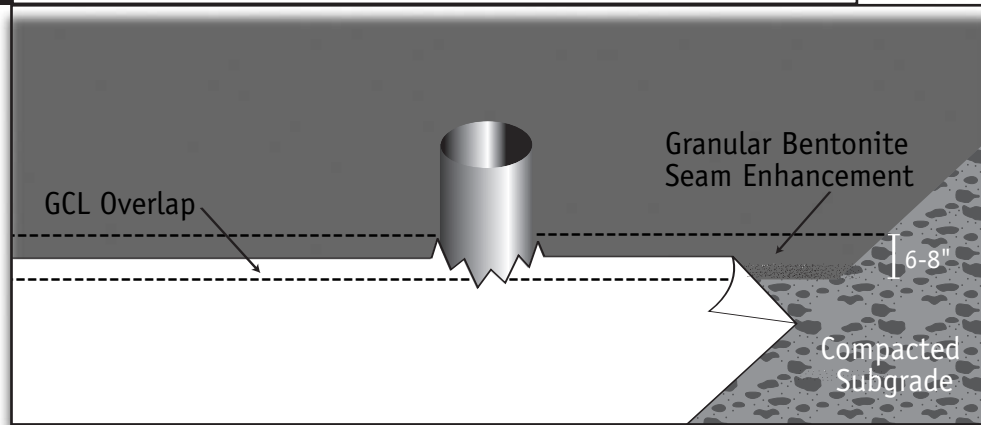
**FIGURE 13A** CROSS-SECTION OF A VERTICAL PENETRATION





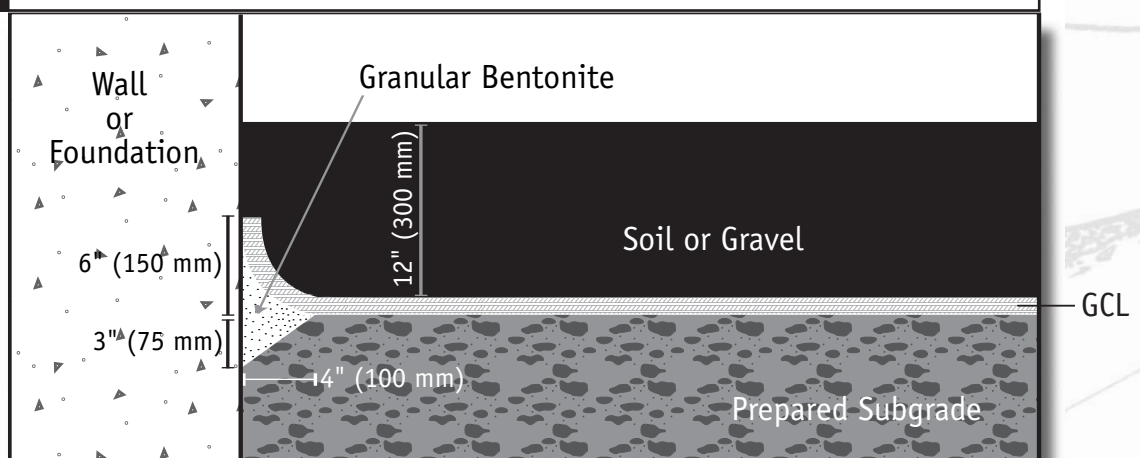
- 8.4 Vertical penetrations are prepared by notching into the subgrade as shown in Figure 13a. The penetration can be completed with two separate pieces of GCL as shown in Figure 13b. Alternatively, a secondary collar can be placed as in Figure 12a or 12b.

**FIGURE 13B ISOMETRIC VIEW OF THE COMPLETED VERTICAL PENETRATION**



- 8.5 When the GCL is terminated at a structure or wall that is embedded into the subgrade on the floor of the containment area, the subgrade should be notched as described in Sections 8.3 and 8.4. The notch is filled with granular bentonite, and the GCL should be placed over the notch and up against the structure (Figure 14). Connection to the structure can be accomplished by placement of soil or stone backfill in this area. When structures or walls are at the top of a slope, additional detailing may be required. Contact CETCO for specific guidance.

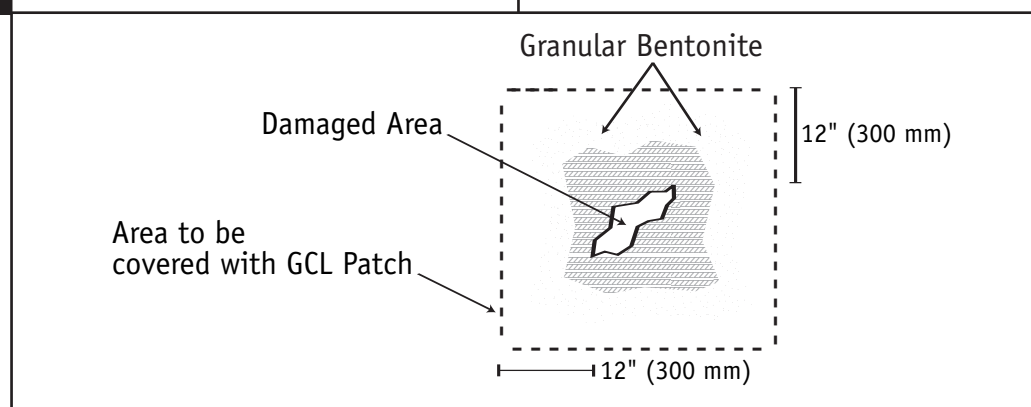
**FIGURE 14 CROSS-SECTION OF GCL SEAL AGAINST AN EMBEDDED STRUCTURE OR WALL**



## DAMAGE REPAIR

- 9.1 If the GCL is damaged (torn, punctured, perforated, etc.) during installation, it may be possible to repair it by cutting a patch to fit over the damaged area (Figure 15). The patch should be cut to size such that a minimum overlap of 12 inches (300 mm) is achieved around all parts of the damaged area. Granular bentonite or bentonite mastic should be applied around the damaged area prior to placement of the patch. It may be necessary to use an adhesive such as wood glue to affix the patch in place so that it is not displaced during cover placement. Smaller patches may be tucked under the damaged area to prevent patch movement.

**FIGURE 15** DAMAGE REPAIR BY PATCHING



## 10 COVER PLACEMENT

- 10.1 The final thickness of soil cover on the GCL varies with the application. A minimum cover layer must be at least 1 foot (300 mm) thick to provide confining stress to the GCL, eliminate the potential for seam separation and prevent damage by equipment, erosion, etc.
- 10.2 Cover soils should be free of angular stones or other foreign matter that could damage the GCL. Cover soils should be approved by the Engineer with respect to particle size, uniformity, and chemical compatibility. Consult CETCO if cover soils with high concentrations of calcium (e.g., limestone, dolomite, gypsum, seashell fragments) are present.
- 10.3 Recommended cover soils should have a particle size distribution ranging between fines and 1 inch (25 mm), unless a cushioning geotextile is specified.
- 10.4 Soil cover shall be placed over the GCL using construction equipment that minimizes stresses on the GCL. A minimum thickness of 1 foot (300 mm) of cover soil should be maintained between the equipment tires/tracks and the GCL at all times during the covering process. In frequently high-traffic areas or roadways, a minimum thickness of 2 feet (600 mm) is required.
- 10.5 Soil cover should be placed in a manner that prevents the soil from entering the GCL overlap zones. Soil cover should be pushed up slopes, not down slopes, to minimize tensile forces on the GCL.



- 10.6 When a textured geomembrane is installed over the GCL, a temporary geosynthetic covering known as a slip sheet or rub sheet should be used to minimize friction during placement and to allow the textured geomembrane to be more easily moved into its final position.
- 10.7 Claymax must be covered with a geomembrane and/or 12" (300 mm) of cover material within 8 hours of deployment to prevent the potential for shrinkage by desiccation.
- 10.8 Cyclical wetting and drying of GCL covered only with geomembrane can cause overlap separation. Soil cover should be placed promptly whenever possible. Geomembranes should be covered with a white geotextile and/or operations layer without delay to minimize the intensity of wet-dry cycling. If there is the potential for unconfined cyclic wetting and drying over an extended period of time, the longitudinal seam overlaps should be increased based on the project engineer's recommendations.
- 10.9 To avoid seam separation, the GCL should not be put in excessive tension by the weight or movement of textured geomembrane on steep slopes. If there is the potential for unconfined geomembrane expansion and contraction over an extended period of time, the longitudinal seam overlaps should be increased based upon the project engineer's recommendations.

## 11

### HYDRATION

- 11.1 Hydration is usually accomplished by natural rainfall and/or absorption of moisture from soil. However, in cases where the containment of non-aqueous liquid is required, it may be necessary to hydrate the covered GCL with water prior to use.
- 11.2 If manual hydration is necessary, water can be introduced by flooding the covered lined area or using a sprinkler system.
- 11.3 If the GCL is hydrated when no confining stress is present, it may be necessary to remove and replace the hydrated material. As discussed in Section 5.8, in many instances, a needlepunch reinforced GCL may not require removal/replacement if the following are true: (1) the geotextiles have not been separated, torn, or otherwise damaged; (2) there is not evidence that the needlepunching between the two geotextiles has been compromised; (3) the Bentomat does not leave deep indentations when stepped upon, and (4) any overlapped seams with bentonite enhancement (see Section 7) are intact.





1500 West Shure Drive    Arlington Heights, IL    60004-1440    TEL 800.527.9948    FAX 847.577.5566    [www.cetco.com](http://www.cetco.com)

©June 2006, CETCO